

# KFC-1673

## SERVICE MANUAL

# KENWOOD

©1990-10 PRINTED IN JAPAN  
B51-6241-00(B)1430

### EXTERNAL VIEW

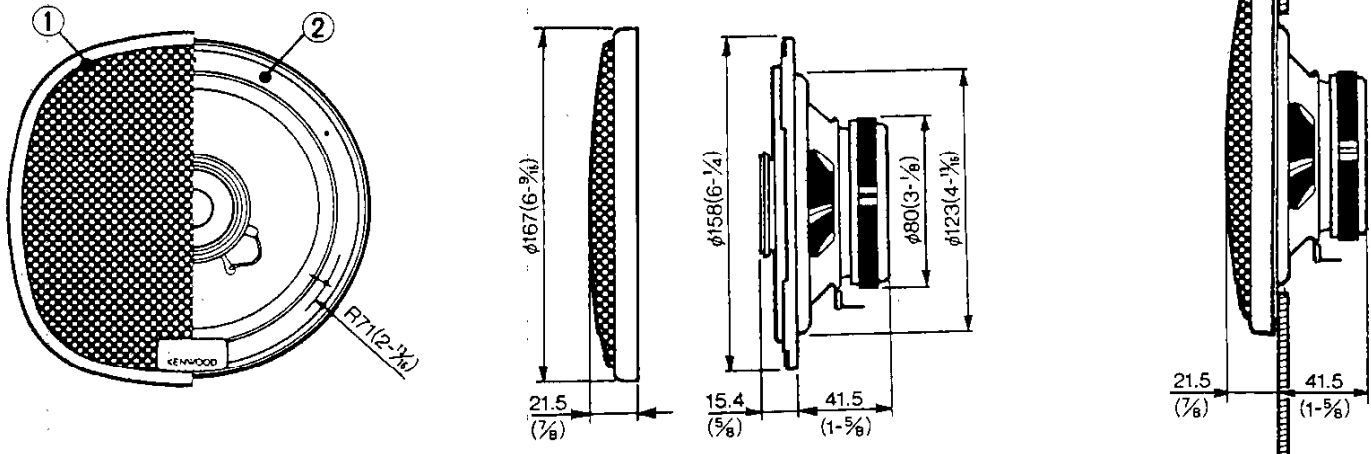

UNIT: mm (inch)

Q.C.  
COPY

### SPECIFICATIONS

#### Speakers

Woofer	16cm(6in) Water proof cone type
	169g(5.9oz) Magnet
Tweeter	5cm(2in) cone type
Peak power	100Watts
Frequency Response	50Hz~20,000Hz
Sensitivity	92dB/W at 1m
Impedance	4 Ohms
Weight per speaker with grille	0.73Kg(1lb 10oz)/pc

We follow a policy of advancements in development.  
For this reason specifications may be changed without notice.

### PARTS LIST

\*New parts

Parts without Parts No. are not supplied.  
Les articles non mentionnés dans le Parts No.  
ne sont pas fournis.  
Teile ohne Parts No. werden nicht geliefert.

Ref No.	New Parts	Parts No.	Description
①		B06-0441-08	GRILLE ASSY
		B46-0100-20	WARRANTY CARD
		E30-5058-08	CORD SET
		N99-1086-08	SCREW SET
②	*	T15-0169-08	SPEAKER